



# **AEP Generation Interconnection**

## **Facilities Study Report**

**For**

**ERAS-2025-001**

**ERAS-2025-005**

**Danville – North Magazine 161 kV Line**

**Yell County, AR**

**April 2026**

## 1 Facilities Study Summary

American Electric Power (AEP) Southwest Transmission Planning performed the following study at the request of the Southwest Power Pool (SPP) for SPP Generation Interconnection request ERAS-2025-001; ERAS-2025-005. Per the SPP Generator Interconnection Procedures (GIP), SPP requested that AEP perform an Interconnection Facilities Studies (IFS) for Network Upgrade(s) in accordance with Section 8.11 for the following Interconnection and/or Network Upgrade(s):

### 1.1 Project Description

ERAS-2025-005 proposes to connect a 150 MW solar/storage generator in Yell County, AR (Figure 2). The point of interconnection for the generator will be AEP's 161 kV Danville to North Magazine transmission line (Figure 1).

### 1.2 AEP's Scope of Work to Facilitate Interconnection

- To accommodate the interconnection to AEP's existing 161 kV Danville to North Magazine transmission line, a new 161 kV, 3-breaker ring bus station will be installed. Also, AEP will complete any necessary remote end work at the North Magazine station associated with this project. The design and construction of the new station will meet all AEP specifications. Bus work and disconnect switches will be designed to accommodate the loading requirements, and circuit breakers will be rated to ensure adequate load and fault interrupting capability. AEP will own, operate, and maintain the new 161 kV ring bus station.
- Installation of associated protection and control equipment, SCADA, and revenue metering will be required at the new 161 kV ring bus station. AEP reserves the right to specify the final acceptable configuration considering design practices, future expansion, and compliance requirements.
- AEP will extend one span of 161 kV transmission line from the generator's terminal at the new 161 kV ring bus station to the ERAS-2025-005 POI. AEP will build and own the first transmission line structure outside of new 161 kV ring bus station, to which AEP's transmission line conductor will attach. Right of Way (ROW) will be required for this span.
- It is understood that the Interconnection Customer is responsible for all of the connection costs associated with interconnecting ERAS-2025-005 to the AEP transmission system. The cost of the customer's generating facility and the costs for the line connecting the generating facility to AEP's transmission system (Beyond the first

span exiting the POI) are not included in this report; these are assumed to be the Customer's responsibility.

- The customer will be responsible for the cost of constructing a fiber-optic connection from their telecom equipment to AEP's new 161 kV ring bus station.
- Work will need to be completed at the Interconnection Customer Station. Sub-metering will be needed for the solar and battery facilities since they share the same gen tie line into the new station.

### 1.3 Short Circuit Evaluation

- It is standard practice for AEP to recommend replacing a circuit breaker when the current through the breaker for a fault exceeds 100% of its interrupting rating with recloser de-rating applied, as determined by the ANSI/IEEE C37.5-1979, C37.010-1979 & C37.04-1979 breaker rating methods.
- In the AEP system, no breakers were found to exceed their interrupting capability after the addition of the generation and related facilities. Therefore, there are no additional short circuit upgrade costs associated with the ERAS-2025-001; ERAS-2025-005 interconnection.

### 1.4 Stability Evaluation

- The stability analysis for the ERAS-2025-001 cluster will be completed in conjunction with the 2026 ITP. AEP will complete their evaluation of the results as part of that effort.

### 1.5 Interconnection Cost of Facilities Included in the Facilities Study:

|  |                     |
|--|---------------------|
| Network Upgrades (Build new 161 kV 3-breaker ring bus station) | \$13,962,995        |
| Transmission Owner Interconnection Facilities (TOIF)           | \$3,735,736         |
| Remote End Work  | \$581,990           |
| Sub-Metering   | \$229,051           |
| <b>Total Cost</b>  | <b>\$18,509,772</b> |

*The estimates do not include the impact that delays in obtaining ROW, permits, or other approvals may have.*

### 1.6 Project Lead time

Project in-service date is projected to be 36 months after the issuance of Authorization to Proceed from the Interconnection Customer.

Figure 1: Point of Interconnection (POI INFORMATION) One-Line Diagram

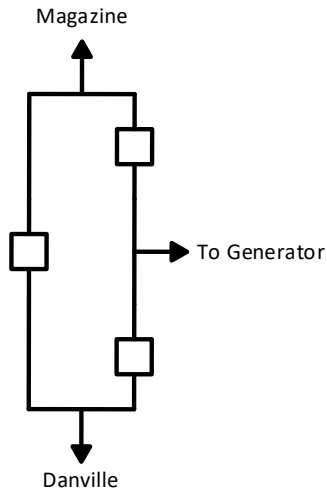

Figure 2: Point of Interconnection Map

